



Jeśli potrzebujesz rozgrzewki



Obejrzyj film

docwiczenia.pl
Kod: M5VR6E

1 Zapisz ceny w złotych.



76 gr



8 gr



45 gr

2 Podaj wymiary owadów w centymetrach.





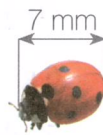

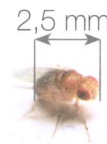

3 Odczytaj wskazania wag.

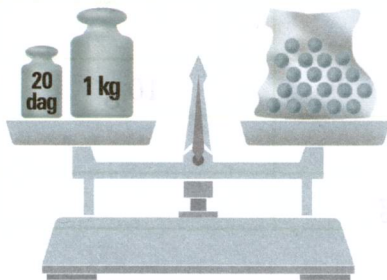

_____ kg

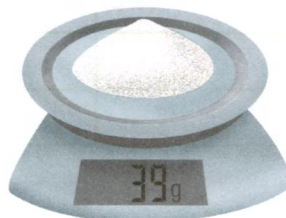

_____ kg

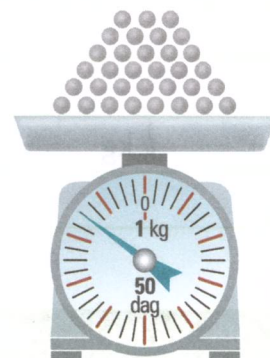

_____ kg

4 Uzupełnij.

$14 \text{ mm} = \text{_____ cm}$

$423 \text{ cm} = \text{_____ m}$

$1875 \text{ m} = \text{_____ km}$

$127 \text{ mm} = \text{_____ cm}$

$56 \text{ cm} = \text{_____ m}$

$629 \text{ m} = \text{_____ km}$

$6 \text{ mm} = \text{_____ cm}$

$9 \text{ cm} = \text{_____ m}$

$7 \text{ m} = \text{_____ km}$

$30 \text{ cm } 2 \text{ mm} = \text{_____ cm}$

$1 \text{ m } 5 \text{ cm} = \text{_____ m}$

$83 \text{ m} = \text{_____ km}$

5 Połącz kolejno kropki odpowiadające długościom:

- 25 m,
- 0,7 km,
- 0,007 km,
- 1400 m,
- 140 m,
- 2800 cm,
- 280 cm,
- 1900 mm,
- 19 cm.

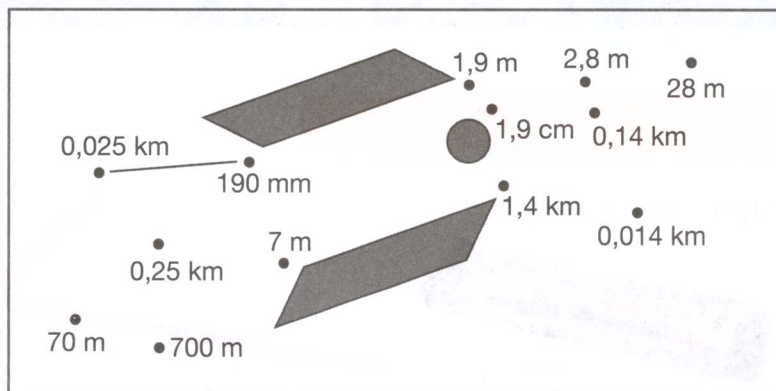

6 Uzupełnij.

$274 \text{ g} = \text{---} \text{ dag}$

$342 \text{ dag} = \text{---} \text{ kg}$

$1634 \text{ kg} = \text{---} \text{ t}$

$83 \text{ g} = \text{---} \text{ dag}$

$70 \text{ dag} = \text{---} \text{ kg}$

$824 \text{ kg} = \text{---} \text{ t}$

$4 \text{ g} = \text{---} \text{ dag}$

$6 \text{ g} = \text{---} \text{ kg}$

$2 \text{ kg} = \text{---} \text{ t}$

$5 \text{ dag } 7 \text{ g} = \text{---} \text{ dag}$

$57 \text{ dag } 8 \text{ g} = \text{---} \text{ kg}$

$43 \text{ kg} = \text{---} \text{ t}$

7 Uzupełnij tabelę.

Kilogramy		Dekagramy	Gramy
$\frac{1}{4} \text{ kg}$	0,25 kg	25 dag	250 g
	0,5 kg		
			10 g
$\frac{1}{8} \text{ kg}$			
		9 dag	



Dla dociekliwych

8 Uzupełnij. Pamiętaj, że cyfry po przecinku nie oznaczają minut.

$0,1 \text{ godz.} = \underline{0,1 \cdot 60 \text{ min} = 6 \text{ min}} \quad 3 \text{ min} = \underline{\frac{3}{60} \text{ godz.} = \frac{1}{20} \text{ godz.} = 0,05 \text{ godz.}}$

$0,2 \text{ godz.} = \underline{\hspace{2cm}} \quad 18 \text{ min} = \underline{\hspace{2cm}}$

$0,15 \text{ godz.} = \underline{\hspace{2cm}} \quad 45 \text{ min} = \underline{\hspace{2cm}}$

$1,5 \text{ godz.} = \underline{\hspace{2cm}} \quad 96 \text{ min} = \underline{\hspace{2cm}}$